

Gruppo / Group 01

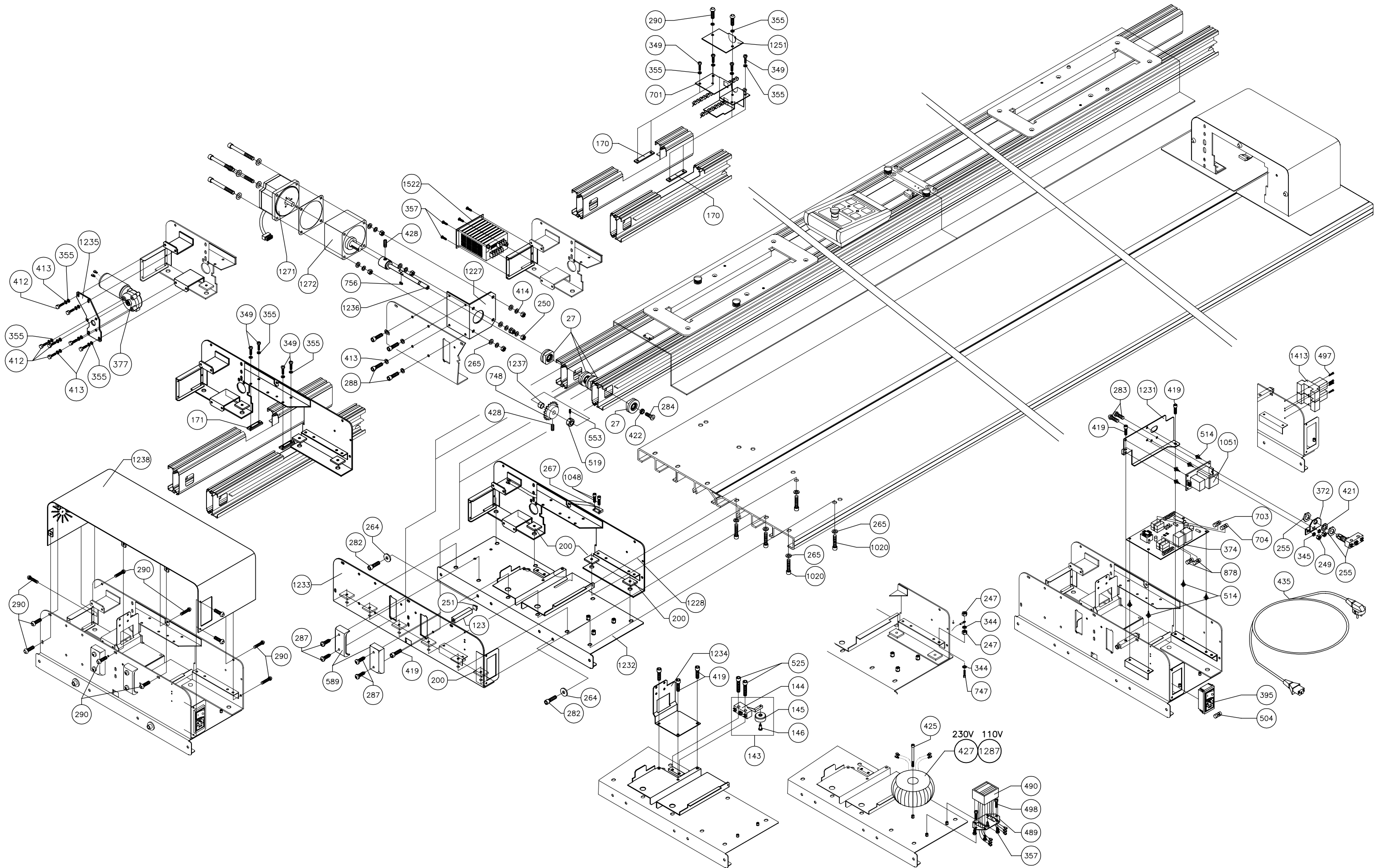

Gruppo / Group **02**

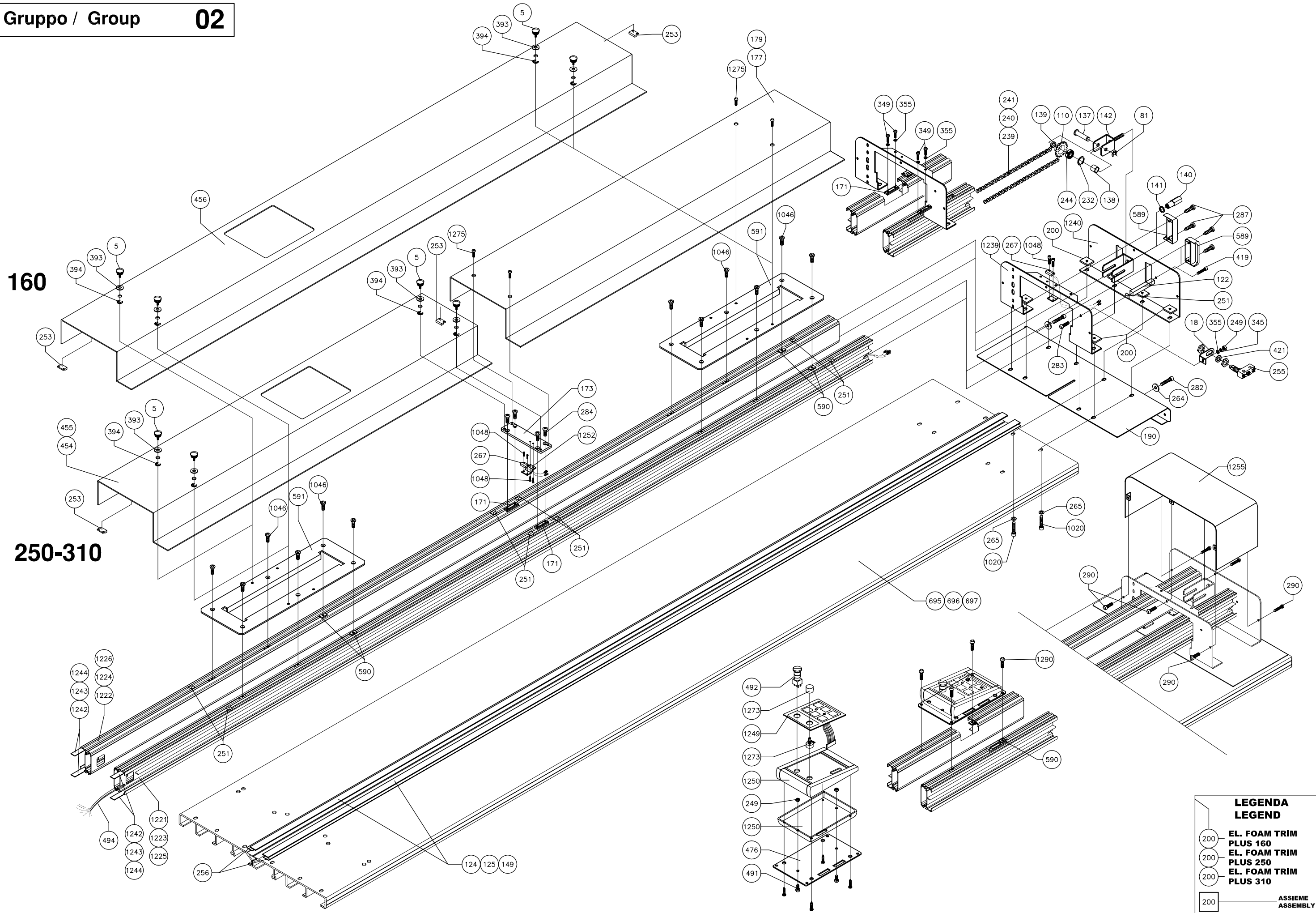

Gruppo / Group 03

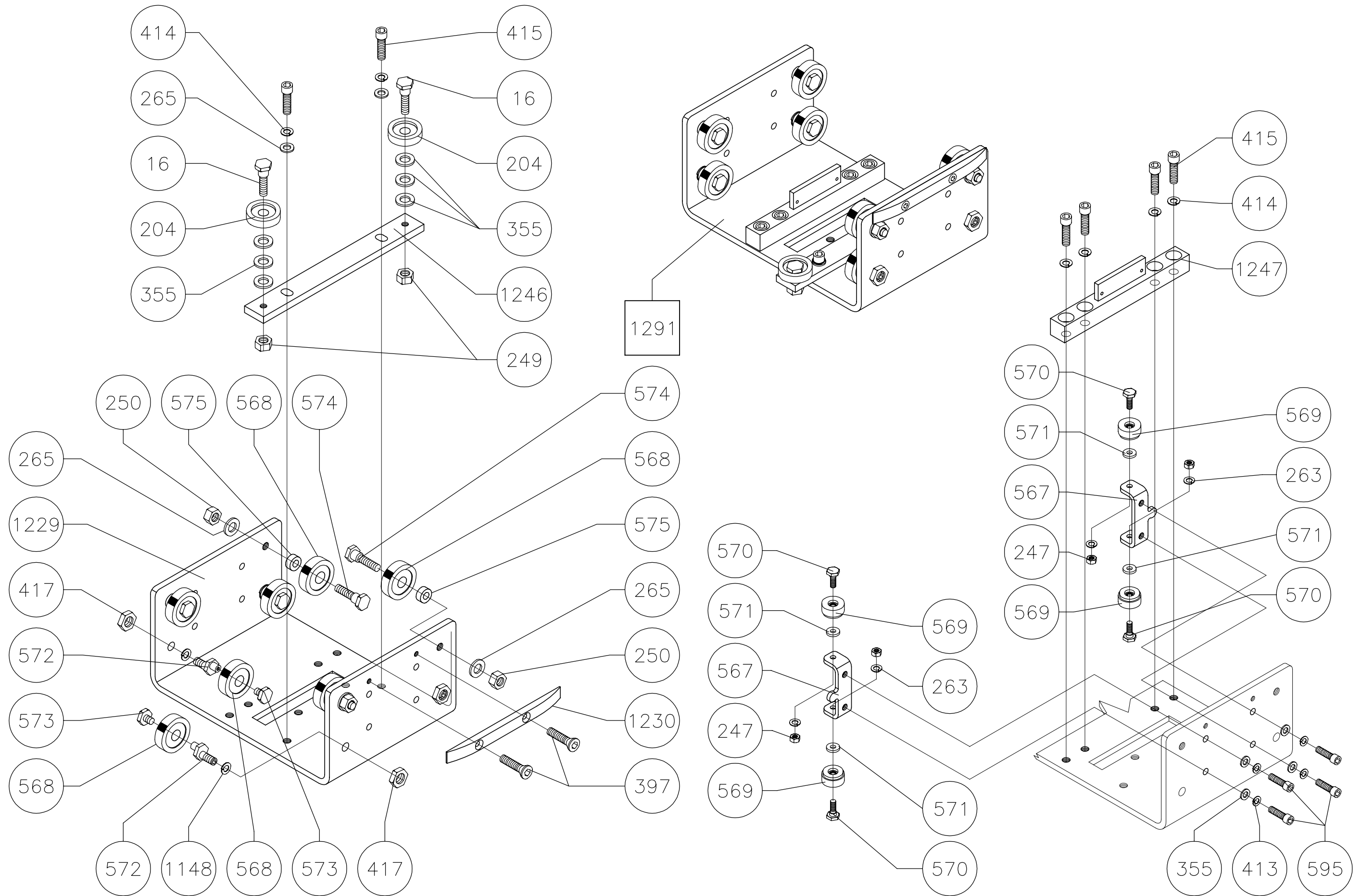

Gruppo / Group **04**

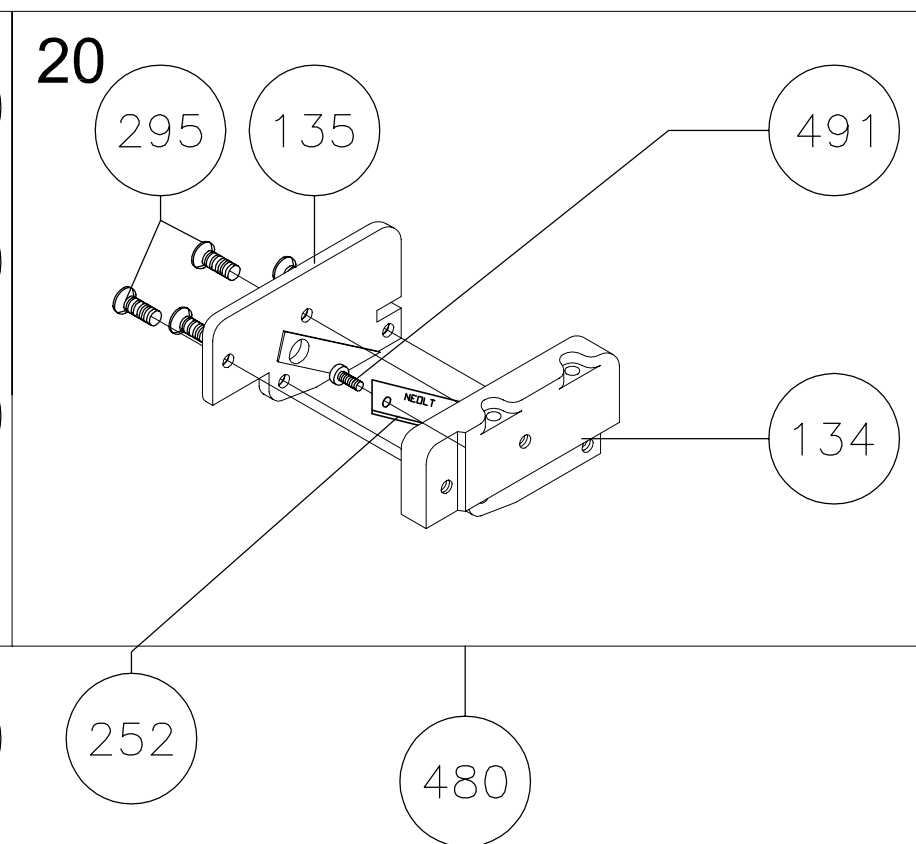
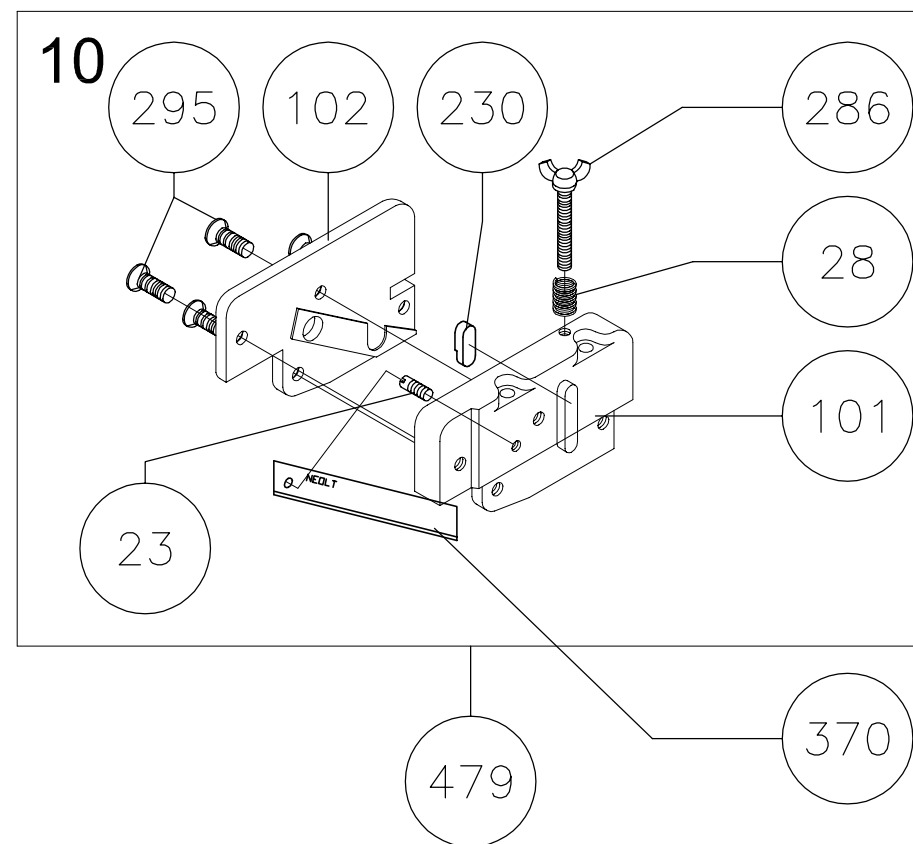
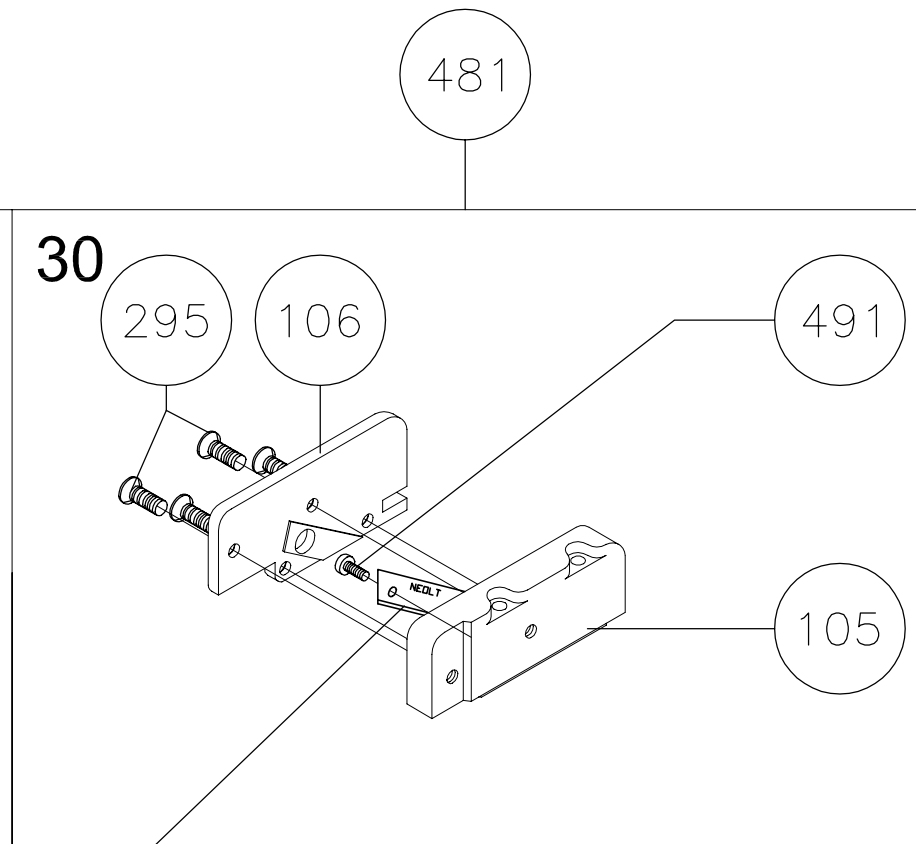
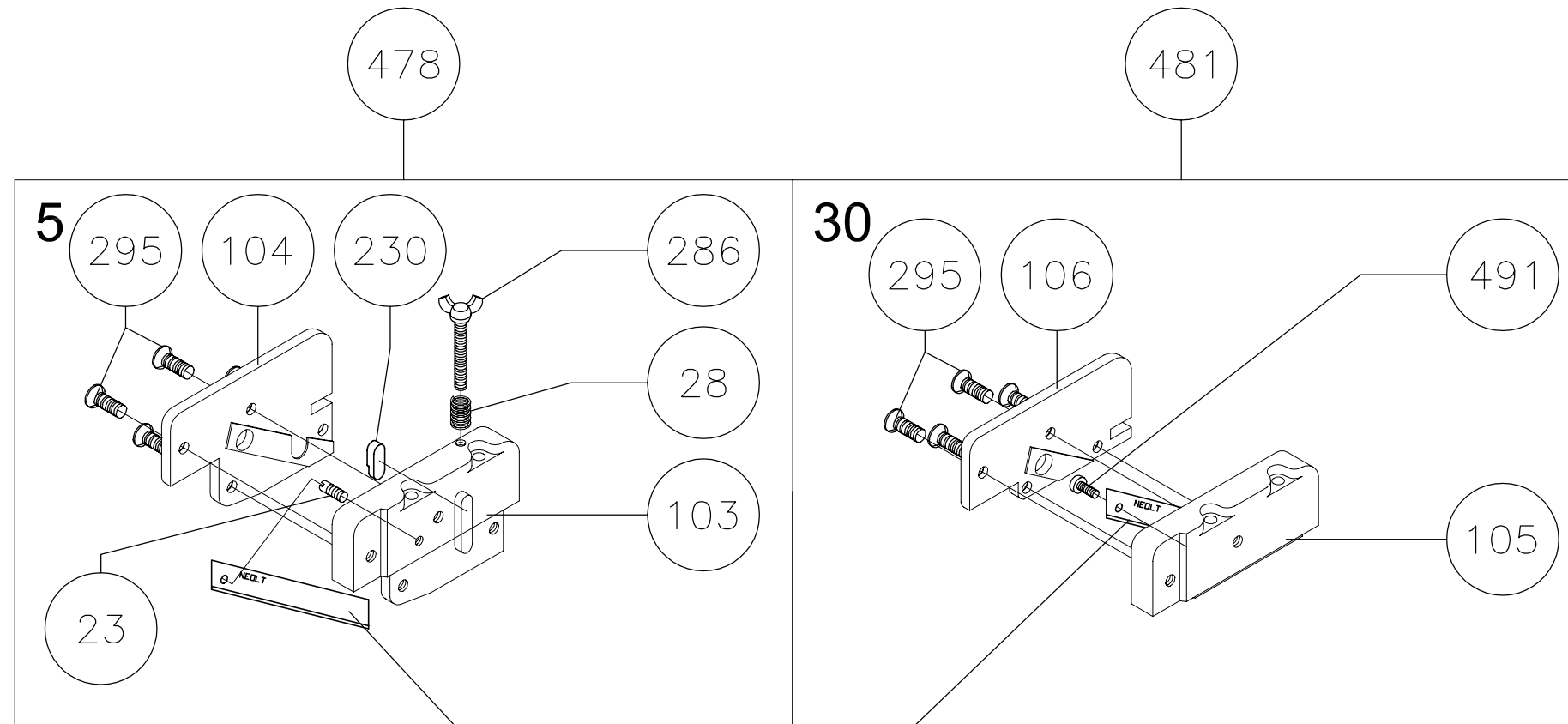
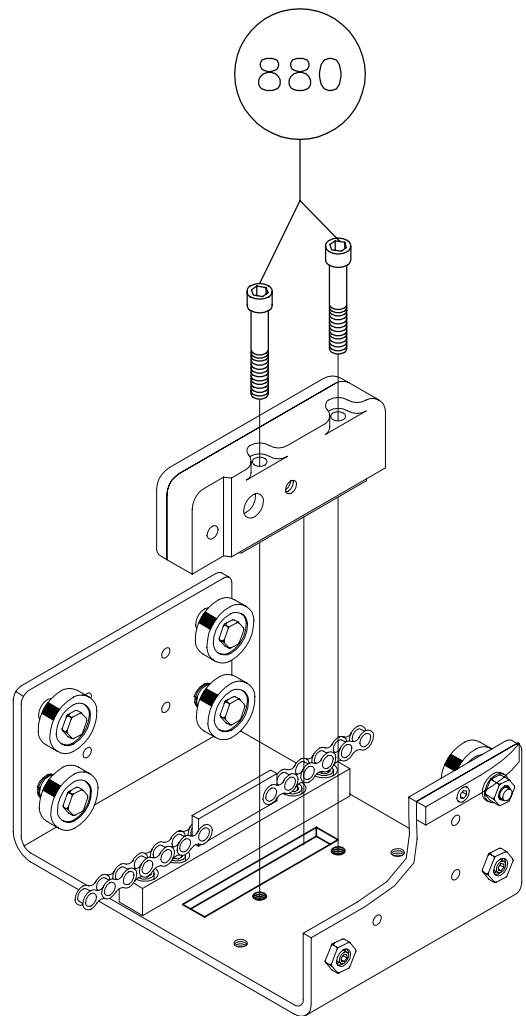

Gruppo / Group 05

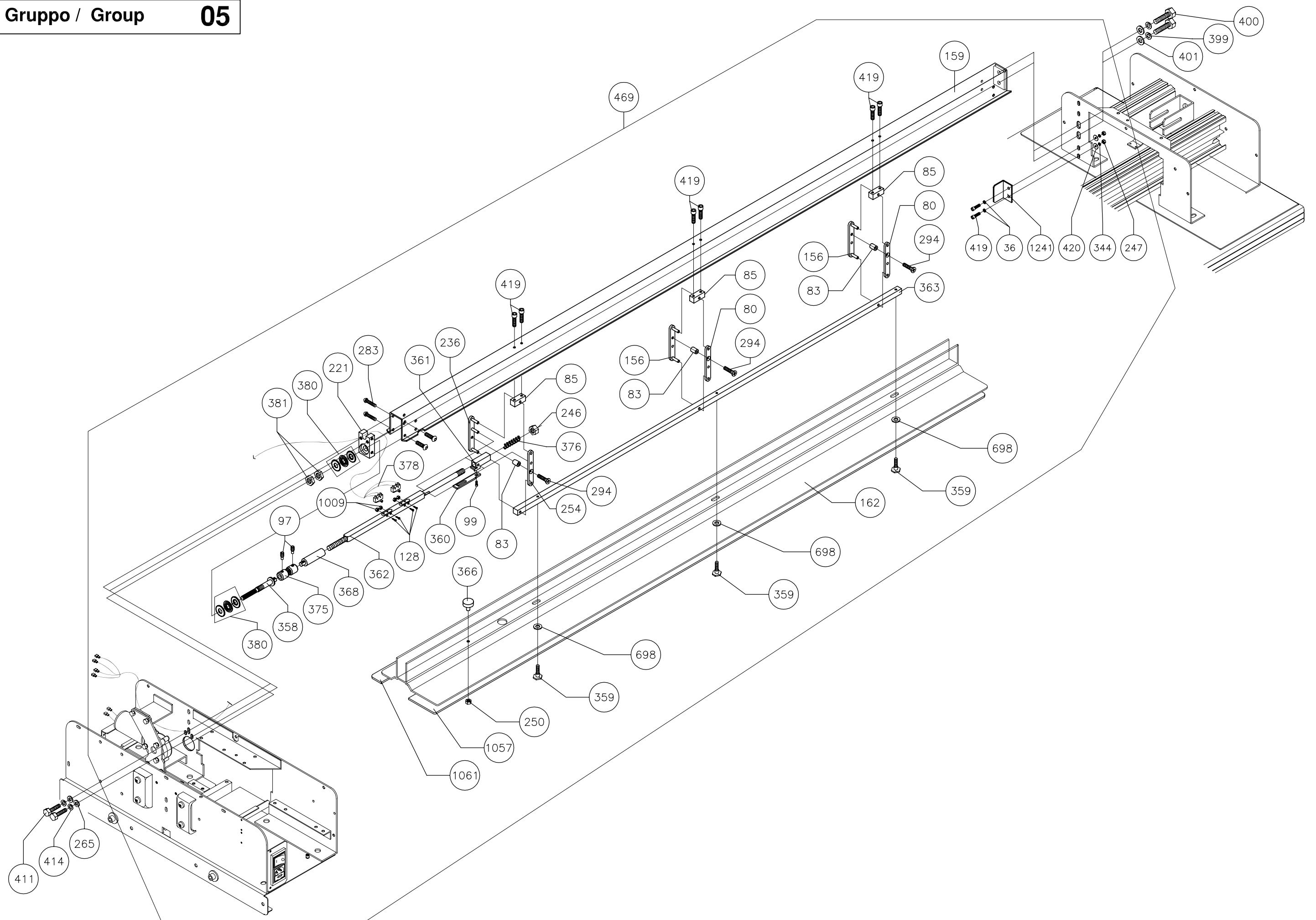

Gruppo / Group 06

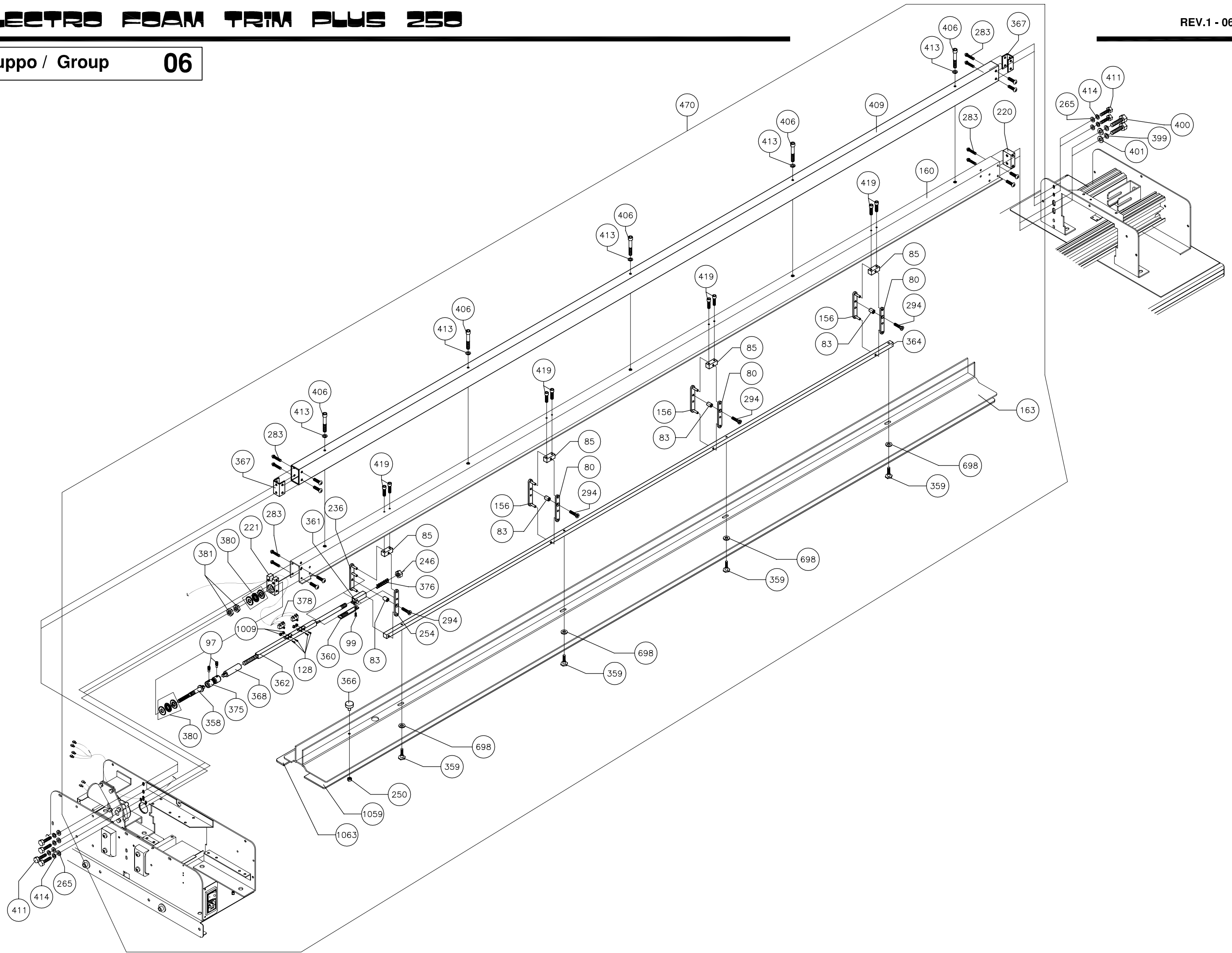

Gruppo / Group 07

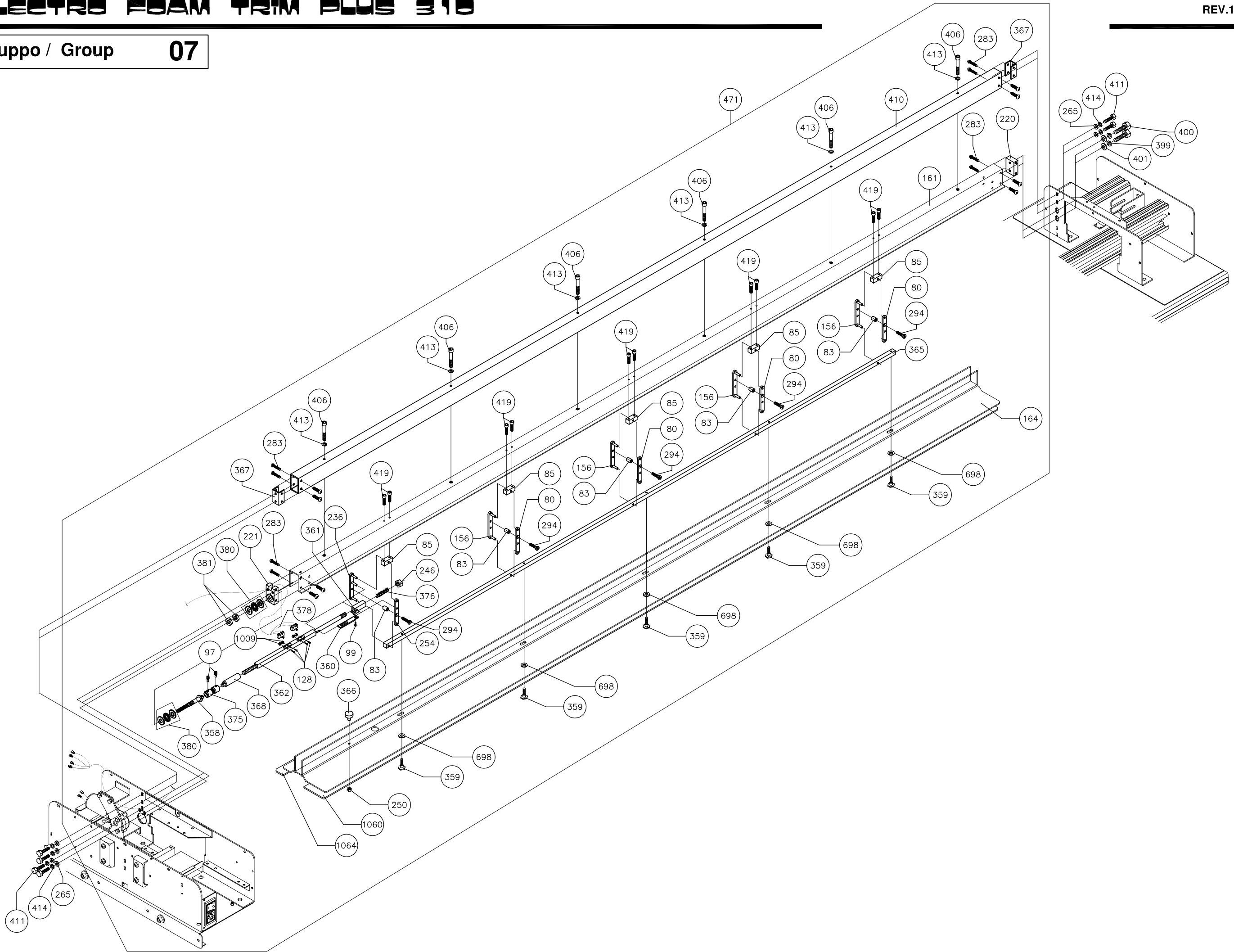

Gruppo / Group 08

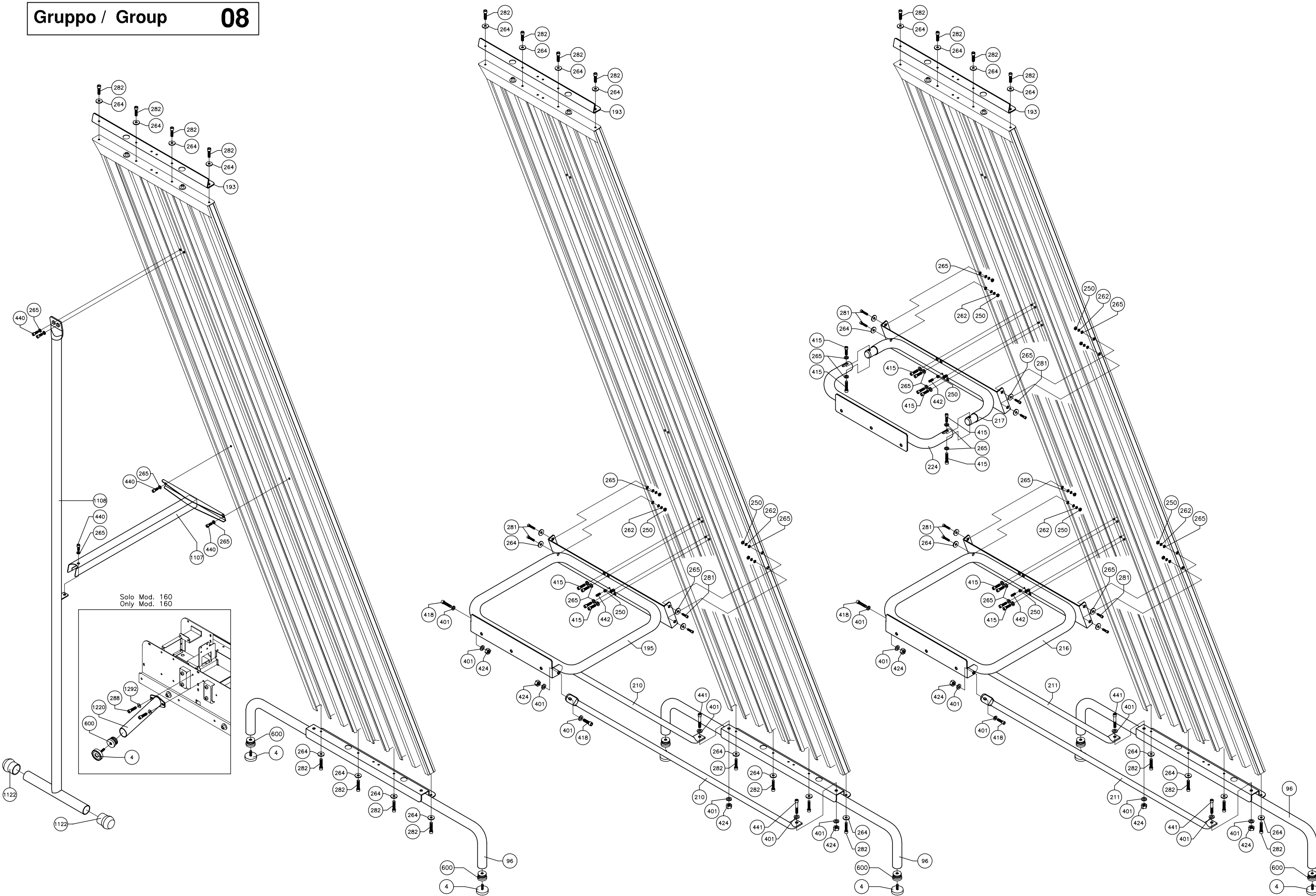

Gruppo / Group 09

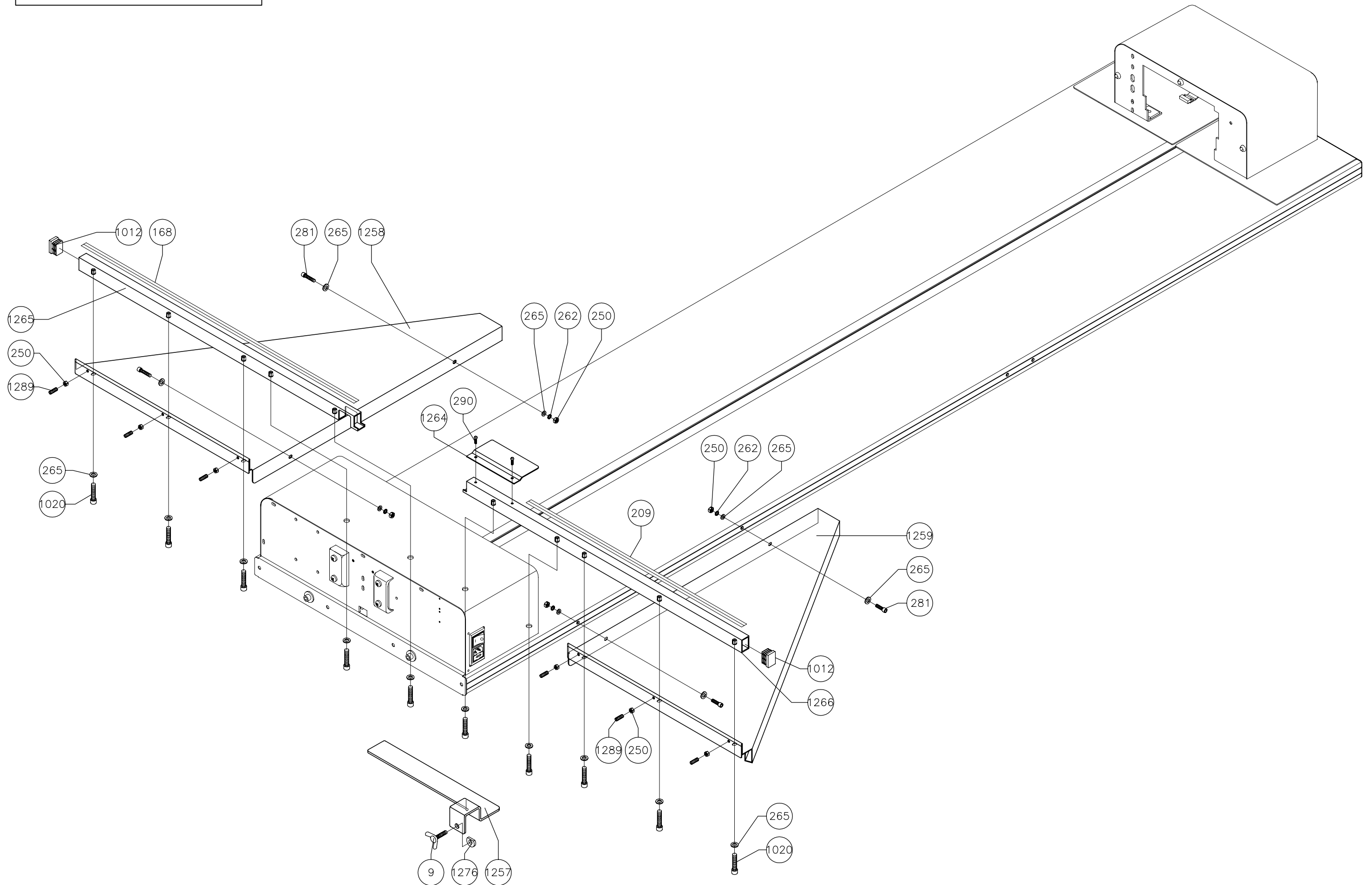

Gruppo / Group 10

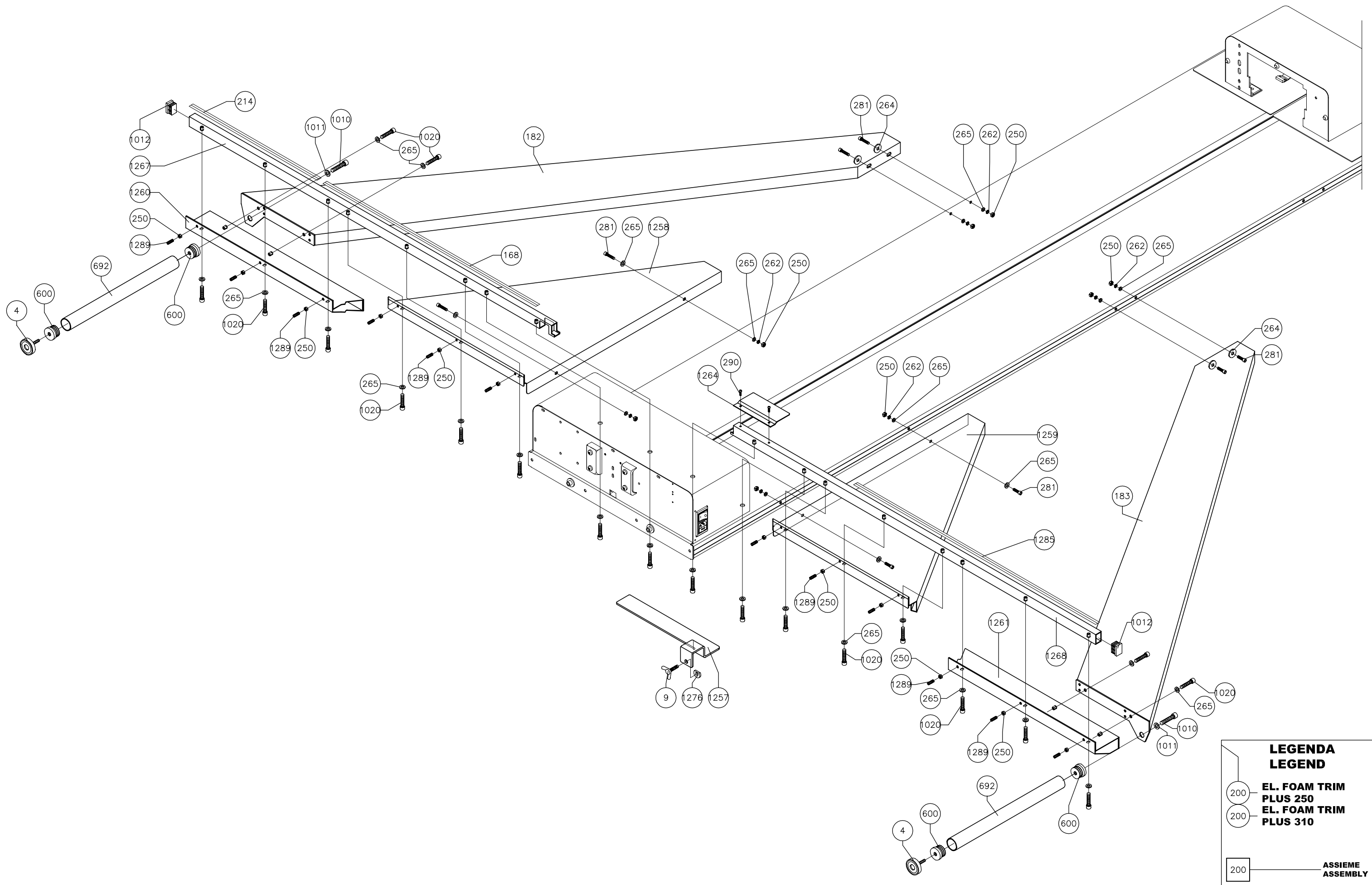

**LEGENDA
LEGEND**

200 EL. FOAM TRIM PLUS 250
200 EL. FOAM TRIM PLUS 310

200 ASSIEME
ASSEMBLY

Gruppo / Group **11**
Opzionale / Optional

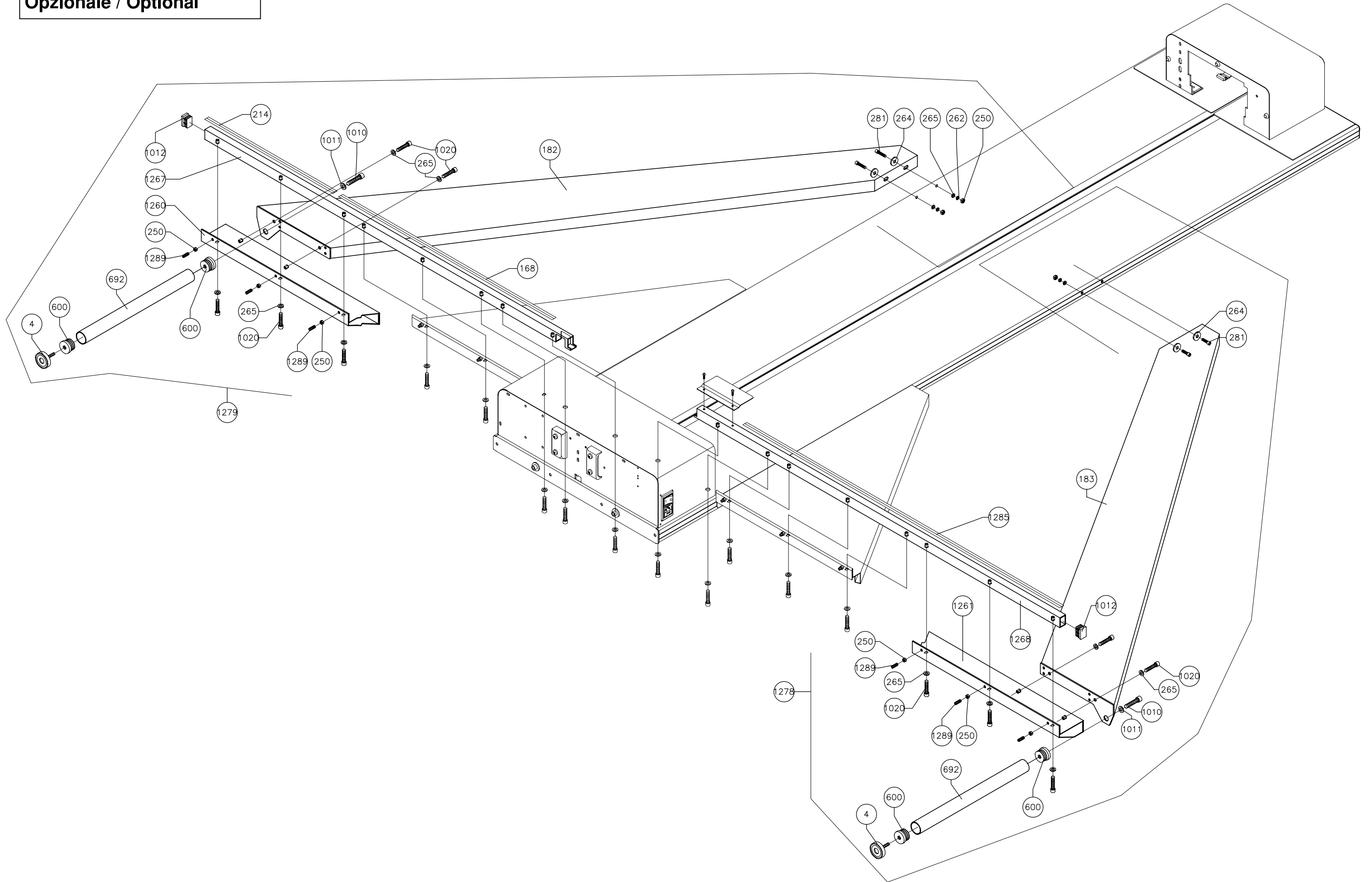

Gruppo / Group **12**
Opzionale / Optional

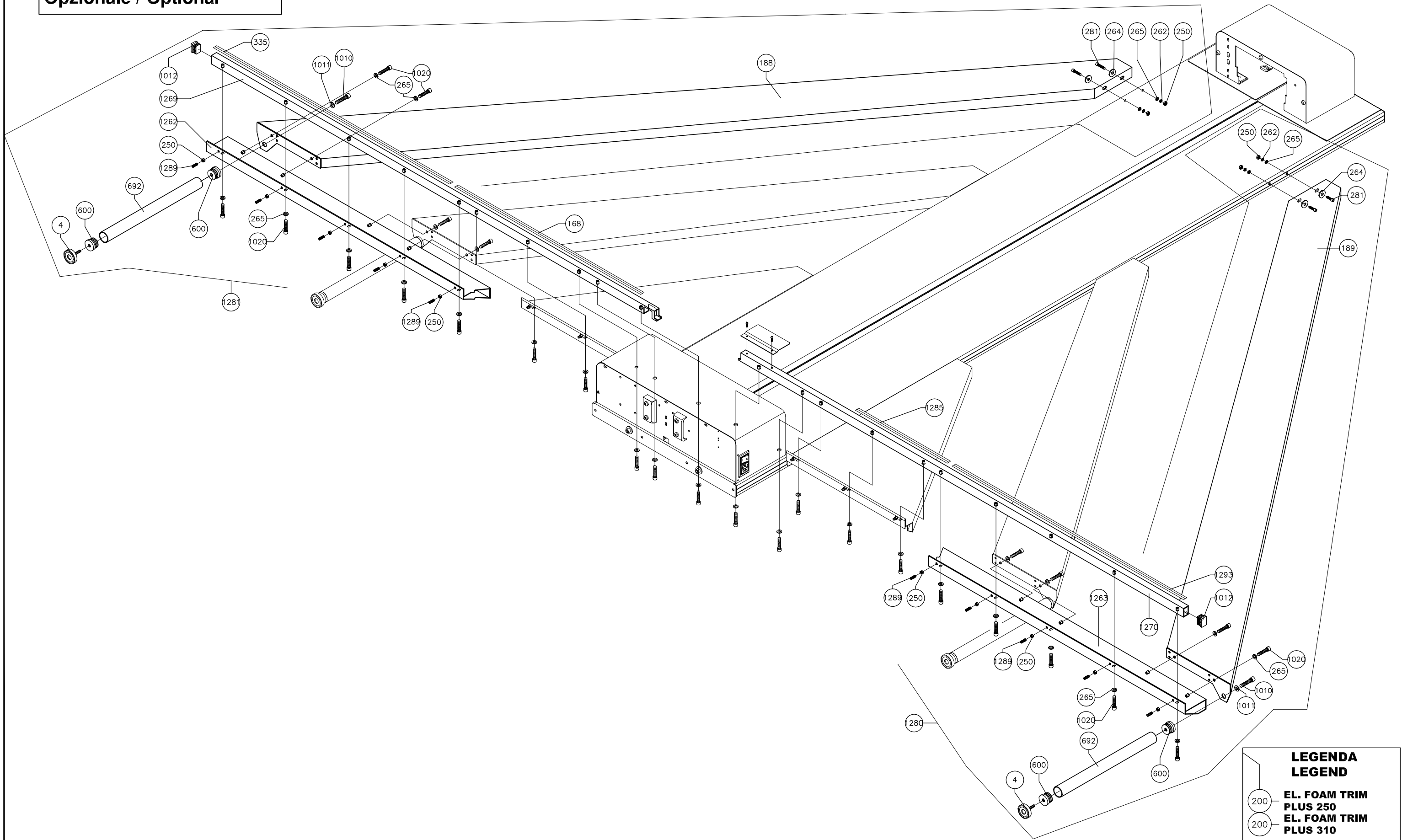

**LEGENDA
LEGEND**

- 200 EL. FOAM TRIM PLUS 250
- 200 EL. FOAM TRIM PLUS 310
- 200 **ASSIEME
ASSEMBLY**

Gruppo / Group **13**
 Opzionale / Optional

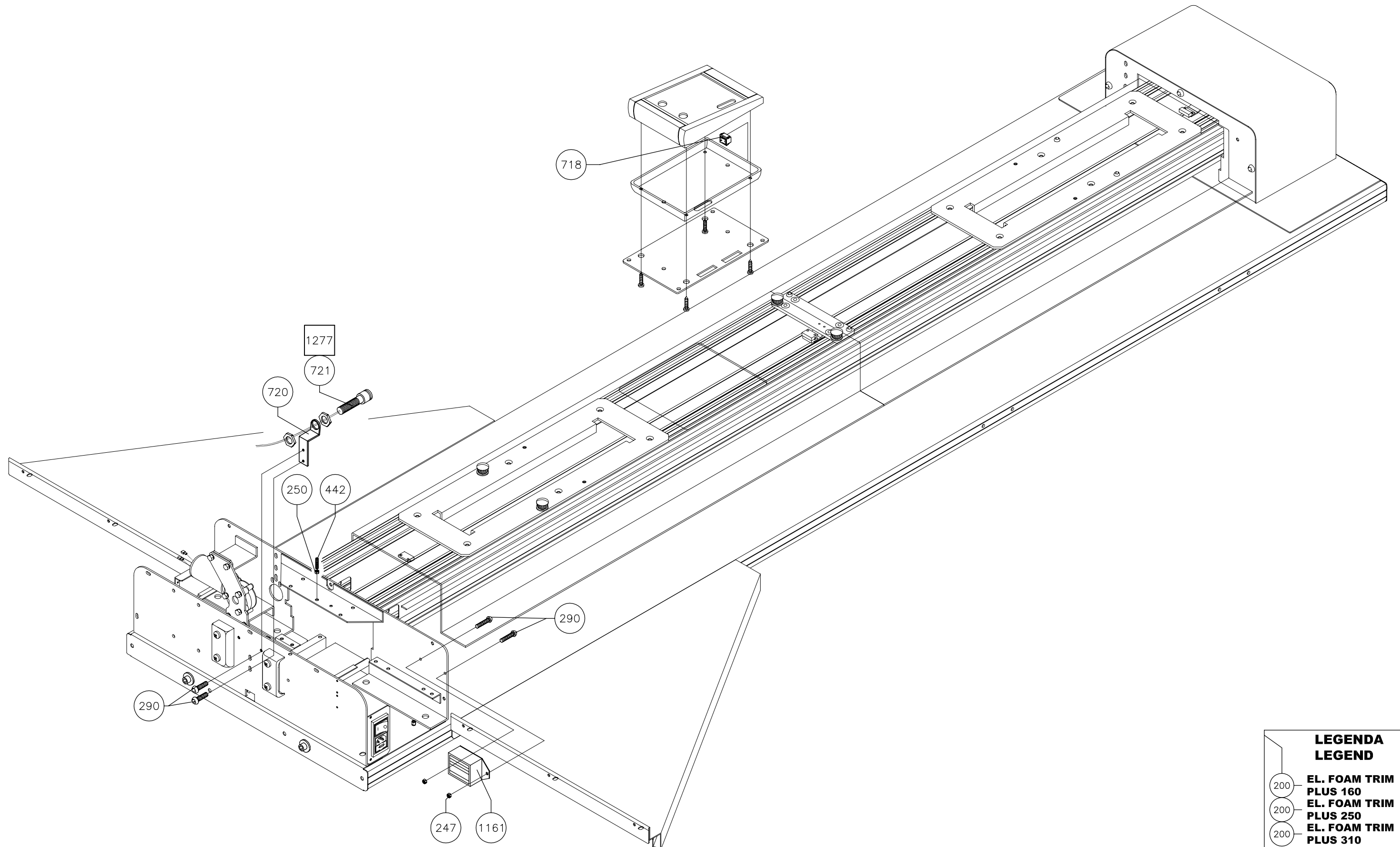

LEGENDA LEGEND	
200	EL. FOAM TRIM PLUS 160
200	EL. FOAM TRIM PLUS 250
200	EL. FOAM TRIM PLUS 310
200	ASSIEME ASSEMBLY

C		ELECTRO FOAM TRIM PLUS			22/09/2006		
POS	11060	DESCRIZIONE	DESCRIPTION	CODICE / CODE	160	250	310
5		Volantino	Handweel	09MA0003803F0	4	4	4
9		Galletto filettato	Threaded wing nut	1DMP4204056F0	1	1	1
16		Perno x carrucola	Bearing pin	1DMM0704125AN	2	2	2
18		Portamico	MSW holder	1EMM1404238AN	1	1	1
23		Perno fermo lama portalama speciale	Blade stop pin for special blade holder	19MM0704672AZ	2	2	2
27		Boccola	Bush	09CA0004940F0	4	4	4
28		Molla x portalama speciale	Spring for the special blade holder	19MO0005506AZ	2	2	2
80		Piastrina di collegamento	Linking plate	1GMM0015274AB	2	3	4
81		Anello elastico (BENZING)	(BENZING) elastic ring	2B008000000AA	1	1	1
83		Distanziale x piastrine	Plates spacer	1GMM0015278AB	3	4	5
85		Piastrina fulcro	Fulcrum plate	1GMM0015289AB	3	4	5
97		Grano con estremità cilindrica M6x10 UNI 5925	M.6x10 UNI 5925 cylindrical edge grub screw	2G406010000AA	2	2	2
99		Vite TCCE M4x5 UNI 5931	M.4x6 UNI 7687 TCCE Screw	2VN04005000AB	1	1	1
101		Portalama anteriore taglio 10mm	10mm cutting front blade holder	1GMM0015355AA	1	1	1
102		Portalama posteriore taglio 10mm	10mm cutting back blade holder	1GMM0015356AA	1	1	1
103		Portalama anteriore taglio 5mm	5mm cutting front blade holder	1GMM0015357AA	1	1	1
104		Portalama posteriore taglio 5mm	5mm cutting back blade holder	1GMM0015358AA	1	1	1
105		Portalama anteriore taglio 30mm	30mm cutting front blade holder	1GMM0015359AA	1	1	1
106		Portalama posteriore taglio 30mm	30mm cutting back blade holder	1GMM0015360AA	1	1	1
110		Pignone x tendicatena	Chain driving toothed weel	0GPG0015366AA	1	1	1
122		Fermo alto	Upper lock	1GMM0015397AZ	1	1	1
123		Fermo basso	Lower lock	1GMM0015398AZ	1	1	1
124		Lama fissa x piano di lavoro	Fixed blade for work table	1GLA0015404AV	2		
125		Lama fissa x piano di lavoro	Fixed blade for work table	1GLA0015405AV		2	

* Per questi componenti indicare la tensione di alimentazione

* For these components, pls indicate the input voltage

POS	DESCRIZIONE	DESCRIPTION	CODICE / CODE	160	250	310
128	Vite TC M2x12	M.2x12 TC Screw	2VS02012000AA	4	4	4
134	Portalama anteriore taglio 20mm	20mm cutting front blade holder	1GMM0015429AA	1	1	1
135	Portalama posteriore taglio 20mm	20mm cutting back blade holder	1GMM0015430AA	1	1	1
137	Alberino x ruota dentata	Shaft for toothed weel	1GMM0015443AB	1	1	1
138	Bussola distanziale x ruota dentata lunga	Spacing bush for toothed weel	1GMM0015444AZ	1	1	1
139	Bussola distanziale x ruota dentata corta	Spacing bush for toothed weel	1GMM0015445AZ	1	1	1
140	Dado x tirante	Nut for tie rod	1GMM0015446AZ	1	1	1
141	Rondella x tirante	Washer for tie rod	1GMM0015447AA	1	1	1
142	Assieme tirante	Tie rod assembly	1GMM0015448AZ	1	1	1
143	Assieme micro/consenso	MSW/Consent assembly	0GMM0015452VW	1	1	1
144	Microinterruttore consenso	MSW/Consent	0GMM0015452AA	1	1	1
145	Rotella x micro/consenso movimentazione	Roller for MSW/Consent movement	1GMP0015454FB	1	1	1
146	Perno x micro/consenso	Pin for MSW/Consent	1GMM0015455AZ	1	1	1
149	Lama fissa x piano di lavoro	Fixed blade for work table	1GLA0015464AV			2
156	Assieme piastrina di collegamento x premifoglio	Linking plate assembly for sheet holder	0GMM0015515AB	2	3	4
159	Assieme profilo x premifoglio	Sheet holder profile assembly	0GLC0015532AV	1		
160	Profilo x premifoglio	Sheet holder profile	0GPM0016110AA		1	
161	Profilo x premifoglio	Sheet holder profile	0GPM0016111AA			1
162	Barra premifoglio	Sheet holder bar	1GLS0015535AV	1		
163	Barra premifoglio	Sheet holder bar	1GLS0015536AV		1	
164	Barra premifoglio	Sheet holder bar	1GLS0015537AV			1
168	Striscia millimetrata x prolunga SINISTRA	Millimetric scale for left extension	1GAD0015943AA	1	1	1
170	Contropiastrina x copripignone	Counter-plate for pinion cover	1GMM0015556AZ	2	2	2
171	Contropiastrina x collegamento profilo	Counter-plate for profile connection	1GMM0015558AZ	4	6	6
173	Piastra di collegamento profili	Profiles linkage plate	1GMM0015560AV		1	1

* Per questi componenti indicare la tensione di alimentazione

* For these components, pls indicate the input voltage

POS	DESCRIZIONE	DESCRIPTION	CODICE / CODE	160	250	310
177	Copertura ALTA in policarbonato	Plexiglas cover	1GMP4415566LT		1	
179	Copertura ALTA in policarbonato	Plexiglas cover	1GMP4415568LT			1
182	Assieme prolunga 2 sinistra inclinata	2nd left slope extension assembly	0GLC0015594AV		1	1
183	Assieme prolunga 2 destra inclinata	2nd right slope extension assembly	0GLC0015595AV		1	1
190	Guida laterale alta	Upper side guide	1GLS0015407AV	1	1	1
200	Piastrina fissaggio spallette	Shoulders fixing plate	1GMM0015646AR	18	18	18
204	Ruota di spinta laterale x carello	Carriage side push wheel	1GMP0015661FB	2	2	2
209	Striscia millimetrata x prolunga DESTRA	Millimetric scale for right extension	1GAD0015944AA	1		
214	Striscia millimetrata x prolunga 2 SINISTRA	Millimetric scale for 2nd left extension	1GAD0015945AA		1	1
220	Flangia x premifoglio	Sheet holder flange	1GMM0015751AZ		1	1
221	Flangia x premifoglio	Sheet holder flange	1GMM0015752AB	1	1	1
230	Chiavetta ribassata x portalama speciale	Blade locking key for special blade holder	1GMM0015934AA	2	2	2
232	Anello elastico x interno (Seeger) D26	(INTERNAL SEEGER) elastic ring	2E026000000AA	1	1	1
236	Assieme piastrina di collegamento x premifoglio	Plate for sheet holder	1GMM0016089AB	1	1	1
239	Catena Passo 8mm 505 passi Lung.4040	Chain, Pitch 8mm L.4040	5GCT0015	1		
240	Catena Passo 8mm 729 passi Lung.5832	Chain, Pitch 8mm L.5832	5GCT0016		1	
241	Catena Passo 8mm 867 passi Lung.6936	Chain, Pitch 8mm L. 6936	5GCT0017			1
244	Cuscinetto	Bearing	59CU0005	1	1	1
246	Dado M10 UNI 5588-65	M.10 UNI 5588 Nut	2D210000000AZ	1	1	1
247	Dado M4 UNI 5588-65	M.4 UNI 5588-65 Nut	2D204000000AZ	6	6	6
249	Dado M5 UNI 5588-65	M.5 UNI 5588-65 Nut	2D205000000AZ	5	5	5
250	Dado M6 UNI 5588-65	M.6 UNI 5588-65 Nut	2D206000000AN	15	29	29
251	Gommino SJ 5018	SJ 5018 rubber plug	5GGO0006	6	10	10
252	Lama di taglio	Cutting blade	1GLA0018511AA	5	5	5
253	Magnete x sensore prossimità M4	Magnet for proximity M4 sensor	5BMG0001	2	2	2

* Per questi componenti indicare la tensione di alimentazione

* For these components, pls indicate the input voltage

POS	DESCRIZIONE	DESCRIPTION	CODICE / CODE	11066		
				160	250	310
254	Piastrina di collegamento premifoglio	Plate for electric sheet holder	1GMM0016091AB	1	1	1
255	Microinterruttore a rotella	Roller MSW	6GMC0016	2	2	2
256	Nastro biadesivo	Tape adhesive on both sides	59RO0005	4,2m	6m	8m
262	Rondella dentellata esterna ø6 UNI 6798	External crinkle washer ø6 UNI 6798	2R206000000AZ	6	10	14
263	Rondella elastica Grower ø4 UNI 1751	Grower spring washer ø4	2R304000000AZ	4	4	4
264	Rondella grembialina mm.6x18	Apron washer mm.6x18	2R006018000AZ	4	4	4
265	Rondella piana ø6 UNI 6592	ø6 UNI 6592 Washer	2R006000000AZ	31	66	70
267	Sensore magnetico	Magnetic sensor	6BSE0002	2	2	2
282	Vite TCCE M6x 25 UNI 5931	M6x25 UNI 5931 TCCE Screw	2VN06025000AZ	4	4	4
283	Vite TBEI M5x10 DIN 7380	M5x10 DIN 7380 TBEI Screw	2VG05010000AB	11	19	19
284	Vite TPSCE M5x10 UNI 5933	M5x10 UNI 5933 TPSCE Screw	2VL05010000AB	1	5	5
286	Vite ad alette UNI 5449 M.6x50	UNI 5449 M.6x50 Wing screw	2V306050000AZ	2	2	2
287	Vite autofilettante TC Croce mm.3,5x31,7 UNI7981	mm.3,5x31,7 UNI7981 TC Self-threading screw	2A203531700AZ	8	8	8
288	Vite TCCE M5x10 UNI 5931	M5x10 UNI 5931 TCCE Screw	2VN05010000AB	4	4	4
290	Vite TBEI M4x10 DIN 7380	M.4x10 DIN 7380 TBEI Screw	2VG04010000AB	21	21	21
292	Vite TC Croce M5x6 UNI 7687	M5x6 UNI 7687 TC Screw	2VV05006000AZ	2	2	2
294	Vite TPS Croce M5x20 UNI 7688	M.5x20 UNI 7688 TPS Screw	2VH05020000AZ	3	4	5
295	Vite TPSCE M6x12 UNI 5933	M.6x12 UNI 5933 TPSCE Screw	2VL06012000AZ	16	16	16
344	Rondella dentellata esterna ø4	MM.4 external crinckle washer	2R204000000AZ	2	2	2
345	Rondella dentellata esterna ø5	MM.5 external crinckle washer	2R205000000AZ	3	3	3
352	Vite TPSCE M4x16 UNI 5933	M.4x6 UNI 5933 TPSCE Screw	2VL04016000AB	2	2	2
355	Rondella piana ø5 UNI 6592	mm.5 UNI 6592 flat washer	2R005000000AZ	34	34	34
357	Vite Aut. TC croce 3,5x9,5 UNI-7981	3,5x9,5 UNI-7981 TC Screw	2A203509500AZ	8	8	8
358	Albero motore x premifoglio	Driving shaft for sheet holder	1GMM0015998AB	1	1	1
359	Vite x barra premifoglio	Sheet holder screw	1GMM0016109AZ	3	4	5

* Per questi componenti indicare la tensione di alimentazione

* For these components, pls indicate the input voltage

POS	DESCRIZIONE	DESCRIPTION	CODICE / CODE	160	250	310
360	Piastra x piattino di scorrimento	Plate for saucer of slide	1GMM0016037AZ	1	1	1
361	Piattino di scorrimento x tirante	Saucer of slide for connecting rod	1GMM0016036AB	1	1	1
362	Tirante mobile x albero motore	Connecting rod for shaft motor	1GMM0016003AB	1	1	1
363	Barra fulcro x premifoglio	Bar fulcrum for sheet holder	1GBR0016092AA	1		
364	Barra fulcro x premifoglio	Bar fulcrum for sheet holder	1GBR0016093AA		1	
365	Barra fulcro x premifoglio	Bar fulcrum for sheet holder	1GBR0016094AA			1
366	Fermo x premifoglio	Sheet holder lock	1GMM0016043AB	1	1	1
367	Attacco x barra superiore premifoglio	Junction for sheet holder	1GMM0016123AZ		2	2
368	Tirante fisso albero motore	Connecting rod for shaft motor	1GMM0016002AB	1	1	1
370	Lama da taglio speciale	Special cutting blade	1GLA0018508AA	5	5	5
372	Squadretta x microinterruttore	Microswitch plate	1GMM0016011AV	1	1	1
374	Scheda elettronica movimento carrello	Electronic card	6GSC0016008	1	1	1
375	Giunto x albero motore premifoglio	Splice for sheet holder shaft motor	1GMM0016000AA	1	1	1
376	Molla x tirante mobile premifoglio	Spring for connecting rod	1GMM0016077AA	1	1	1
377	Motoriduttore 431-003 x premifoglio	Gearmotor for electric sheet holder	6GMT0015995	1	1	1
378	Microinterruttori cablati	Microswitch	6BMC0003Z	1	1	1
380	Cuscinetto assiale a sfere id.51100 SBC	Bearing	5ECU0043	2	2	2
381	Dado ribassato passo fine M10x1,25	Nut M.10x1,25 UNI 5589	2D610000012AZ	2	2	2
393	Rondella x copertura in policarbonato	Washer	1GMP0016618F0	4	4	4
394	Anello elastico di sicurezza ad espansione (BENZING)	(BENZING) UNI 7434-5 elastic ring	2B005000000AA	4	4	4
395	Interruttore con alimentazione	Power button	6QPR0009	1	1	1
399	Rondella elastica Grower ø8 UNI 1751	Grower spring washer ø8 UNI 1751	2R308000000AZ	2	2	2
400	Vite TE M8x25 UNI 5739	M8x25 UNI 5739 TE Screw	2VA08025000AZ	2	2	2
401	Rondella piana ø8 UNI 6592	ø8 UNI 6592 Flat washer	2R008000000AZ	2	2	2
406	Vite TCCE M5x60 UNI 5931	M.5x60 UNI 5931 TCCE Screw	2VN05060000AZ		5	6

* Per questi componenti indicare la tensione di alimentazione

* For these components, pls indicate the input voltage

POS	DESCRIZIONE	DESCRIPTION	CODICE / CODE	160	250	310
409	Barra superiore premifoglio	Upper bar for sheet holder	1GLS0016117AV		1	
410	Barra superiore premifoglio	Upper bar for sheet holder	1GLS0016118AV			1
411	Vite TE M6x20 UNI 5739	M6x20 UNI 5739 TE Screw	2VA06020000AB	2	6	6
412	Vite TE M5x16 UNI 5739	M5x15 UNI 5739 TE Screw	2VA05016000AN	7	7	7
413	Rondella elastica Grower ø5 UNI 1751	Grower spring washer ø5 UNI 1751	2R305000000AA	15	19	20
414	Rondella elastica Grower ø6 UNI 1751	Grower spring washer ø6 UNI 1751	2R306000000AZ	12	16	16
415	Vite TCCE M6x14 UNI 5931	M6x14 UNI 5931 TCCE Screw	2VN06014000AZ	26	26	28
417	Dado M7 speciale	M.7 special nut	1DMM5305344AN	4	4	4
419	Vite TCCE M4x10 UNI 5931	M4x10 UNI 5931 TCCE Screw	2VN04010000AZ	13	15	17
421	Rondella dentellata esterna ø12 UNI 6798	External crinkle washer ø12 UNI 6798	2R212000000AA	2	2	2
422	Rondella x albero motore/ruota	Washer for shaft motor	1GMM0015374AZ	1	1	1
425	Vite TCCE M5x35 UNI 5931	M.5x35 UNI 5931 TCCE Screw	2VN05035000AZ	1	1	1
427	Trasformatore toroidale	Toroidal transformer	6GTR0014K	1	1	1
428	Grano punta piana M8x10	M.8x10 Flat point grub screw	2G608010000AA	2	2	2
435	Cavo di alimentazione 3x0,75 nero	Power cable	69CC0004	1	1	1
442	Grano punta piana M6x20 UNI 5923	M.6x20 UNI 5923 Flat point grub screw	2G106020000AA		2	4
454	Copertura BASSA in policarbonato	Plexiglas cover	1GMP4415565LT		1	
455	Copertura BASSA in policarbonato	Plexiglas cover	1GMP4415567LT			1
456	Copertura in policarbonato	Plexiglas cover	1GMP4415564LT	1		
469	Gruppo Premifoglio	Fixing bar assembly	-GGRUP-5-160	1		
470	Gruppo Premifoglio	Fixing bar assembly	-GGRUP-6-250		1	
471	Gruppo Premifoglio	Fixing bar assembly	-GGRUP-7-310			1
476	Piastra supporto scatola tastiera	Plate for keyboard box	1GMM0016560AV	1	1	1
478	Portalama completo taglio 5mm	5mm cutting blade holder	1GMM0015357VW	1	1	1
479	Portalama completo taglio 10mm	10mm cutting blade holder	1GMM0015355VW	1	1	1

* Per questi componenti indicare la tensione di alimentazione

* For these components, pls indicate the input voltage

POS	DESCRIZIONE	DESCRIPTION	CODICE / CODE			
				160	250	310
480	Portalama completo taglio 20mm	20mm cutting blade holder	1GMM0015429VW	1	1	1
481	Portalama completo taglio 30mm	30mm cutting blade holder	1GMM0015359VW	1	1	1
489	Piastrina fissaggio filtro rete	Plate	1QMM0016173AZ	1	1	1
490	Filtro antidisturbo	Noise filter	6QFI0016149	1	1	1
491	Vite TC croce M.5x8 UNI 7687	M.5x8 TC Screw	2VV05008000AZ	25	25	25
492	Interruttore d'emergenza	Emergency switch	6QIT0005K	1	1	1
494	Cablaggio completo	Complete wiring	6GCA0129	1	1	1
497	Vite TCCE M3x20	M.3x20 TCCE Screw	2VN03020000AB	4	4	4
498	Vite TC croce M5x12	M.5x12 TC Screw	2VV05012000AZ	2	2	2
499	Ferma fascetta	Clamp fastener	59BF0001	2	2	2
500	Fascetta fermacavi	Wire clamp	59CO0003	12	12	12
504	Fusibile T 2A 250V 5X20	Fuse T 2A 250V 5x20	69FU0035	2	2	2
514	Supporti x scheda	Card support	59SU0004	8	8	8
519	Distanziale x albero di trasmissione	Outdistance her for tree of transmission	1GMM0416222AZ	1	1	1
525	Vite TCCE M4x25 UNI 5931	M4x20 UNI 5931 TCCE Screw	2VN04025000AB	2	2	2
553	Grano M.4x6 UNI-5927	M.4x6 Grub screw	2G204006000AA	1	1	1
567	Piastrina supporto rotelle x carrello	Pulley plate	1GMM1416197AZ	2	2	2
568	Cuscinetto	Bearing	5GCU0047	8	8	8
569	Cuscinetto x rotaia	Bearing	0DCA0004682FB	4	4	4
570	Perno fulcro cuscinetti	Fulcrum pin	1DMM0704850AN	4	4	4
571	Tubetto spessore x cuscinetti	Spacing peg	1DMM0405044AN	4	4	4
572	Perno eccentrico x carrello	Eccentric pin	1DMM0706382AN	4	4	4
573	Vite x perno eccentrico	Eccentric pin screw	1DMM0106383AN	4	4	4
574	Perno x cuscinetto	Bearing pin	1DMM0706384AN	4	4	4
575	Tubetto spessore	Spacing peg	1DMM0402930AN	4	4	4

* Per questi componenti indicare la tensione di alimentazione

* For these components, pls indicate the input voltage

POS	DESCRIZIONE	DESCRIPTION	CODICE / CODE	160	250	310
589	Tappo x rotaia orizzontale	Horizontal rail plug	1DMP1504751F0	4	4	4
590	Piastrina fissaggio supporto/scatola	Plaque fixing I support box	1DMM1404851AN	20	20	20
591	Rinforzo x profili guida carrello	Reinforcement for profiles guide cart	1GLS0016225AV	2	2	2
595	Vite TCCE M5x12 UNI 5931	M5x12 TCCE Screw	2VN05012000AB	4	4	4
616	Vite TCCE M6x35 UNI 5931	M6x35 TCCE Screw	2VN06035000AZ	4	8	12
695	Piano di lavoro completo	Complete work table	0GPI0017740BV	1		
696	Piano di lavoro completo	Complete work table	0GPI0017741AV		1	
697	Piano di lavoro completo	Complete work table	0GPI0017742AV			1
698	Rondella x barra premifoglio ø16 ø7 sp0,7	Washer ø16 ø7 sp0,7	1GMP0017671FB	3	4	5
701	Copripignone	Pinion cover	1GLS0017504BV	1	1	1
703	Fusibile T4A 250V 5X20	Fuse T4A 250V 5X20	69FU0037	1	1	1
704	Fusibile T125mA 250V 5X20	Fuse T125mA 250V 5X20	69FU0038	1	1	1
747	Vite TCCE M4x14 UNI 5931	M4x14 UNI 5931 TCCE Screw	2VN04014000AZ	1	1	1
748	Ruota dentata per catena albero motore	Toothed weel for driving shaft	1GPG0017744AB	1	1	1
756	Linguetta forma A 3x3x10 UNI 6604-69	Locking key A 3x3x10 UNI 6604	2I210003030AA	1	1	1
878	Fusibile T 3,15A 250V 5X20	Fuse T 3,15A 250V 5x20	69FU0024	2	2	2
880	Vite TCCE M6x45 UNI 5931	M6x45 UNI 5931 TCCE Screw	2VN06045000AZ	2	2	2
1009	Dado esagonale ottone M2x1,6	MM.2X1,6 Nut	2D202000000AA	4	4	4
1010	Vite TCCE M10X16 U5931-D912	M10X16 UNI 5931 TCCE Screw	2VN10016000AZ		2	2
1011	Rondella ø10 UNI 6592	Washer MM.10 UNI 6592	2R010000000AZ		2	2
1012	Tappo rettangolare 30X20	Rectangular plug	59TP0011	2	2	2
1019	Ferma fascetta piccolo	Clamp fastener	59BF0002	6	6	6
1020	Vite TCCE M6X20 UNI 7687	M.6X20 UNI 7687 TCCE Screw	2VN06020000AZ	23	37	37
1037	Grano con punta M8X8	M.8x8 grub screw	2G208008000AA	1	1	1
1046	Vite TPSCE M6x10 UNI 5933	M.6x10 TPSCE Screw	2VL06010000AZ	12	12	12

* Per questi componenti indicare la tensione di alimentazione

* For these components, pls indicate the input voltage

POS	DESCRIZIONE	DESCRIPTION	CODICE / CODE	160	250	310
1048	Vite TCCE M3x6 UNI 5931	M.3x6 TCCE Screw	2VN03006000AZ	4	6	6
1051	Scheda elettronica x rele' principale	electronic card for rele'	6GSC0018582	1	1	1
1057	Gomma (nera 73mm) profilo premifoglio 160	Rubber for sheet holder 160 (black 73 mm.)	1GMG0219210F0	1		
1059	Gomma (nera 73mm) profilo premifoglio 250	Rubber for sheet holder 250 (black 73 mm.)	1GMG0219208F0		1	
1060	Gomma (nera 73mm) profilo premifoglio 310	Rubber for sheet holder 310 (black 73 mm.)	1GMG0219207F0			1
1061	Gomma (nera 33mm) profilo premifoglio 160	Rubber for sheet holder 160 (black 33 mm.)	1GMG0219203F0	1		
1063	Gomma (nera 33mm) profilo premifoglio 250	Rubber for sheet holder 250 (black 33 mm.)	1GMG0219205F0		1	
1064	Gomma (nera 33mm) profilo premifoglio 310	Rubber for sheet holder 310 (black 33 mm.)	1GMG0219206F0			1
1221	Profilo DESTRO guida carrello	Profile Right guide cart	1GPM0019344AE	1		
1222	Profilo SINISTRO guida carrello	Profile Left guide cart	1GPM0019345AE	1		
1223	Profilo DESTRO guida carrello	Profile Right guide cart	1GPM0019346AE		1	
1224	Profilo SINISTRO guida carrello	Profile Left guide cart	1GPM0019347AE		1	
1225	Profilo DESTRO guida carrello	Profile Right guide cart	1GPM0019348AE			1
1226	Profilo SINISTRO guida carrello	Profile Left guide cart	1GPM0019349AE			1
1227	Squadretta porta motore	Motor holding bracket	1GMM1719353AZ	1	1	1
1228	Assieme spalletta interna bassa	Together low inside shoulder	0GSP0019355AV	1	1	1
1229	Carrello	Cart	1GCR0019356AZ	1	1	1
1230	Battuta micro x carrello	Micro wisecrack for cart	1GMM0019357AZ	1	1	1
1231	Piastra copri elettronica	Plate you cover electronics	1GMM0019363AV	1	1	1
1232	Assieme guida laterale bassa	Lower side guide assembly	0GLS0019365BV	1	1	1
1233	Assieme spalletta esterna bassa	Together low external shoulder	0GSP0019369AV	1	1	1
1234	Squadretta copri micro	plate you cover micro	1GMM0019377AV	1	1	1
1235	Piastra motore x premifoglio	Plate motor for sheet hoder	1GMM0019402AZ	1	1	1
1236	Albero di collegamento motore x ruota dentata	Tree of connection motor for cogwheel	1GMM0019403AB	1	1	1
1237	Tubetto distanziale x albero motore	Tube outdistance her for tree motor	1GMM0019404AA	1	1	1

* Per questi componenti indicare la tensione di alimentazione

* For these components, pls indicate the input voltage

POS	DESCRIZIONE	DESCRIPTION	CODICE / CODE	160	250	310
1238	Assieme carter basso	Together low carter	0GCT0019405BV	1	1	1
1239	Assieme spalletta interna alta	Together tall inside shoulder	0GSP0019423AV	1	1	1
1240	Assieme spalletta esterna alta	Upper external shoulder assembly	0GSP0019448AV	1	1	1
1241	Squadretta x spalletta interna alta	Plate for tall inside shoulder	1GMM0019450AV	1		
1242	Bandella x profilo guida carrello	Plate for profile guide cart	1GBN0019451AA	4		
1243	Bandella x profilo guida carrello	Plate for profile guide cart	1GBN0019452AA		4	
1244	Bandella x profilo guida carrello	Plate for profile guide cart	1GBN0019453AA			4
1246	Supporto pulegge x carrello	I support pulleys for cart	1GMM0019460AZ	1	1	1
1247	Assieme blocchetto x carrello	Together notepad for cart	1GMM0019461AZ	1	1	1
1249	Tastiera a membrana	Keyboard	1GTT0019798FN	1	1	1
1250	Scatola x tastiera	keyboard box	1GMP0020712FT	1	1	1
1251	Carterino x copripignone	Carter for you cover pinion	1GCT0020713AV	1	1	1
1252	Piastrina portasensore	Plaque microswitch	1GMM0020716AZ		1	1
1253	Rondella ø60 in gomma x trasformatore toroidale	Washer ø60 in rubber for toroidal transformer	1GMG1520756F0	1	1	1
1254	Rondella ø80 in gomma x trasformatore toroidale	Washer ø80 in rubber for toroidal transformer	1GMG1520757F0	1	1	1
1255	Assieme carter alto	Together tall carter	0GCT0020770BV	1	1	1
1257	Guida mobile x riferimento taglio	It drives mobile for reference cut	1GGU0021000AV	1	1	1
1258	Assieme ala SINISTRA x piano	Left extension assembly	0GLS0021036AV	1	1	1
1259	Assieme ala DESTRA x piano	Together wing Right for plain	0GLS0021037AV	1	1	1
1260	Assieme prolunga corta SINISTRA	Together it prolongs short Left	0GLC0021005BV		1	1
1261	Assieme prolunga corta DESTRA	Together it prolongs short Right	0GLC0021008BV		1	1
1264	Paratia di contenimento x guida laterale bassa	Plate of containment for low side guide	1GMM0021015AV	1	1	1
1265	Supporto corto guida bassa SINISTRA	Support short Left low guide	1GSU0021016BE	1		
1266	Supporto corto guida bassa DESTRA	Support short guide low Right	1GSU0021017BE	1		
1267	Supporto medio guida bassa SINISTRA	Support middle Left low guide	1GSU0021018BE		1	1

* Per questi componenti indicare la tensione di alimentazione

* For these components, pls indicate the input voltage

POS	DESCRIZIONE	DESCRIPTION	CODICE / CODE	160	250	310
1268	Supporto medio guida bassa DESTRA	Support middle guide low Right	1GSU0021019BE		1	1
1271	Motore	Motor	6GMO0025	1	1	1
1272	Riduttore	Reduction gear	6GRD0003	1	1	1
1273	Potenziometro	Potentiometer	6GPT0004	1	1	1
1274	Vite TCCE M6x30 UNI 5931	M.6x30 TCCE Screw	2VN06030000AZ	8	16	20
1275	Vite TBEI M6x10 DIN 7380	M6x10 TBEI Screw	2VG06010000AZ		4	4
1276	Rondella x galletto x guida mobile	Washer for mobile guide wing nut	1GMP0221024F0	1	1	1
1285	Striscia millimetrata x prolunga DESTRA	Millimeter crawls for it prolongs Right	1GMP0018915FB		1	1
1288	Vite TCCE M.3x8	M.3x8 TCCE Screw	2VN03008000AZ	4	6	6
1289	Grano punta piana M6x12 UNI 5923	M.6x12UNI 5923 Flat point grub screw	2G106012000AA	6	12	12
1290	Vite TBEI M6x8 DIN 7380	M6x8 TBEI Screw	2VG06008000AZ	4	8	8
1291	Gruppo carrello	Complete carriage	-GGRUP-3-EFTP	1	1	1
1413	Relè bobina 230V	Relè 230V	6GRE0011	2	2	2
1522	Controller azionamento motore	Electronic board for driving motor	6GAL0013K	1	1	1

POS	DESCRIZIONE	DESCRIPTION	CODICE / CODE	160	250	310
	CAVALLETTO	EASEL				
4	Piedini regolabili M10	Adjustable feet (M10)	09PI0003559F0	3	4	4
96	Supporto cavalletto	Stand support	1GSU0015339AV	1	1	1
193	Supporto superiore a muro	Upper wall support	1GLS0015620AV	1	1	1
195	Assieme supporto basso a muro	Lower wall support assembly	0GSU0015627AV		1	
210	Tirante di ancoraggio a muro	Left tie rod for wall fixing	1GTR0015677AV		2	
211	Tirante di ancoraggio a muro	Right tie rod for wall fixing	1GTR0015678AV			2
216	Assieme supporto basso a muro	Lower wall support assembly	0GSU0015691AV			1
217	Assieme ½ supporto alto a muro	1/2 upper wall support assembly	0GSU0015693AV			1
224	Assieme ½ supporto alto a muro	1/2 upper wall support assembly	0GSU0015812AV			1
250	Dado M6 UNI 5588-65	M6 UNI 5588-65 Nut	2D206000000AN		6	12
262	Rondella dentellata esterna ø6 UNI 6798	External crinkle washer ø6 UNI 6798	2R206000000AZ		4	8
264	Rondella grembialina mm.6x18	Apron washer mm.6x18	2R006018000AZ	8	12	16
265	Rondella piana ø6 UNI 6592	ø6 UNI 6592 Washer	2R006000000AZ	5	4	10
282	Vite TCCE M6x 25 UNI 5931	M6x25 UNI 5931 TCCE Screw	2VN06025000AZ	8	8	8
401	Rondella piana ø8 UNI 6592	ø8 UNI 6592 Flat washer	2R008000000AZ		8	8
415	Vite TCCE M6x14 UNI 5931	M6x14 UNI 5931 TCCE Screw	2VN06014000AB	5	8	12
418	Vite TCCE M.8x25 UNI 5931	M8x25 UNI 5931 TCCE Screw	2VN08025000AB		2	2
424	Dado M8 UNI-5588	M.8 nut UNI5588	2D208000000AZ		4	4
440	Vite TCCE M6x12	M.6x12 TCCE Screw	2VN06012000AZ	5		
441	Vite TCCE M8x60	M.8x60 TCCE Screw	2VN08060000AZ		2	2
442	Grano punta piana M6x20 UNI 5923	M.6x20 UNI 5923 Flat point grub screw	2G106020000AA		2	4
600	Puntale nero rotondo alettato-filettato ø35	Plug	5CTP0056	3	6	6
616	Vite TCCE M6x35 UNI 5931	M6x35 TCCE Screw	2VN06035000AZ		4	8

* Per questi componenti indicare la tensione di alimentazione

* For these components, pls indicate the input voltage

POS	110/60	DESCRIZIONE	DESCRIPTION	CODICE / CODE	160	250	310
692		Tubo x gamba prolunga	Tube for leg extends	1GTU0015670AV		2	2
1107		Tirante x cavalletto	Tension bar for stand	0GTR0019712AV	1		
1108		Assieme cavalletto	Stand	0GCV0019721AV	1		
1122		Puntali x scala a pera	Plug for leg	5GPI0013	2		
1220		Assieme piedino antiribaltamento		1GPD0018111AV	1		

POS	DESCRIZIONE	DESCRIPTION	CODICE / CODE	160	250	310
	ESTENSIONE LATERALE	LATERAL ESTENSION				
4	Piedini regolabili M10	Adjustable feet (M10)	09PI0003559F0	2	2	2
168	Striscia millimetrata x prolunga SINISTRA	Millimetric scale for left extension	1GAD0015943AA	1	1	1
182	Assieme prolunga 2 sinistra inclinata	2nd left slope extension assembly	0GLC0015594AV	1		
183	Assieme prolunga 2 destra inclinata	2nd right slope extension assembly	0GLC0015595AV	1		
188	Assieme prolunga 3 sinistra inclinata	3rd left slope extension assembly	0GLC0015614AV		1	1
189	Assieme prolunga 3 destra inclinata	3rd right slope extension assembly	0GLC0015615AV		1	1
214	Striscia millimetrata x prolunga 2 SINISTRA	Millimetric scale for 2nd left extension	1GAD0015945AA	1		
250	Dado M6 UNI 5588-65	M6 UNI 5588-65 Nut	2D206000000AN	9	9	9
262	Rondella dentellata esterna ø6 UNI 6798	External crinkle washer ø6 UNI 6798	2R206000000AZ	4	4	4
265	Rondella piana ø6 UNI 6592	ø6 UNI 6592 Washer	2R006000000AZ	10	10	10
335	Striscia millimetrata x prolunga 3 SINISTRA	Millimetric scale for 3rd left extension	1GAD0015947AA		1	1
415	Vite TCCE M6x14 UNI 5931	M6x14 UNI 5931 TCCE Screw	2VN06014000AB	10	10	10
442	Grano punta piana M6x20 UNI 5923	M6x20 UNI 5923 Flat point grub screw	2G106020000AA	1	1	1
600	Puntale nero rotondo alettato-filettato ø35	Plug	5CTP0056	4	4	4
692	Tubo x gamba prolunga	Tube for leg extends	1GTU0015670AV	2	2	2
1010	Vite TCCE M10X16 U5931-D912	M10X16 UNI 5931 TCCE Screw	2VN10016000AZ	2	2	2
1011	Rondella ø10 UNI 6592	Washer MM.10 UNI 6592	2R010000000AZ	2	2	2
1012	Tappo rettangolare 30X20	Rectangular plug	59TP0011	2		
1260	Assieme prolunga corta SINISTRA	Together it prolongs short Left	0GLC0021005BV	1		
1261	Assieme prolunga corta DESTRA	Together it prolongs short Right	0GLC0021008BV	1		
1262	Assieme prolunga lunga SINISTRA	Together it prolongs long Left	0GLC0021011BV		1	1
1263	Assieme prolunga lunga DESTRA	Together it prolongs long Right	0GLC0021014BV		1	1
1267	Supporto medio guida bassa SINISTRA	Support middle Left low guide	1GSU0021018BE	1		

* Per questi componenti indicare la tensione di alimentazione

* For these components, pls indicate the input voltage

POS	DESCRIZIONE	DESCRIPTION	CODICE / CODE	160	250	310
1268	Supporto medio guida bassa DESTRA	Support middle guide low Right	1GSU0021019BE	1		
1269	Supporto lungo guida bassa SINISTRA	Support long Left low guide	1GSU0021020BE		1	1
1270	Supporto lungo guida bassa DESTRA	Support long guide low Right	1GSU0021021BE		1	1
1278	Estensione laterale destra 2	Right lateral extension 2	Q663DX	1		
1279	Estensione laterale sinistra 2	Left lateral extension 2	Q663SX	1		
1280	Estensione laterale destra 3	Right lateral extension 3	Q664DX		1	1
1281	Estensione laterale sinistra 3	Left lateral extension 3	Q664SX		1	1
1285	Striscia millimetrata x prolunga DESTRA	Millimeter crawls for prolongs Right	1GMP0018915FB	1	1	1
1289	Grano punta piana M6x12 UNI 5923	M.6x12UNI 5923 Flat point grub screw	2G106012000AA	8	8	8
1293	Striscia millimetrata x prolunga DESTRA	Millimeter crawls for prolongs Right	1GMP0018916FB		1	1

POS	DESCRIZIONE	DESCRIPTION	CODICE / CODE	160	250	310
	TRACCIATORE LASER OPZIONALE	LASER RAY OPTIONAL				
36	Rondella piana ø4 UNI 6592	ø4 Flat washer	2R004000000AZ	2	2	2
247	Dado M4 UNI-5588	M.4 nut UNI5588	2D204000000AZ	2	2	2
250	Dado M6 UNI-5588	M.6 nut UNI5588	2D206000000AN	1	1	1
290	Vite TBEI M4x10 DIN 7380	M.4x10 DIN 7380 TBEI Screw	2VG04010000AB	2	2	2
419	Vite TCCE M4x10 UNI 5931	M4x10 UNI 5931 TCCE Screw	2VN04010000AB	2	2	2
442	Grano punta piana M6x20 UNI 5923	M.6x20 UNI 5923 Flat point grub screw	2G106020000AA	1	1	1
718	Interruttore Marquardt 1801-1146	Interrupter	6AIN0011	1	1	1
720	Squadretta supporto laser	Laser bracket	1GMM1717505AV	1	1	1
721	Laser	Laser	6GLS0001	1	1	1
1161	Alimentatore cablato per laser	Power Supply laser	6GAL0006	1	1	1
1277	Kit tracciatore laser	Kit laser ray	Q677	1	1	1